



深圳市创威时代光电有限公司
Shenzhen ChuangWei Seculens CO., Ltd.

产品规格书 Product Specification

型号:

(Model Name) : SECULENS 6mm F1.0 1068-HD+IR0688

编码:

(Part No.) :

客户名称:

(Customer Name) :

客户编码:

(Customer Part No.) :

客户承认 (Customer Approved)

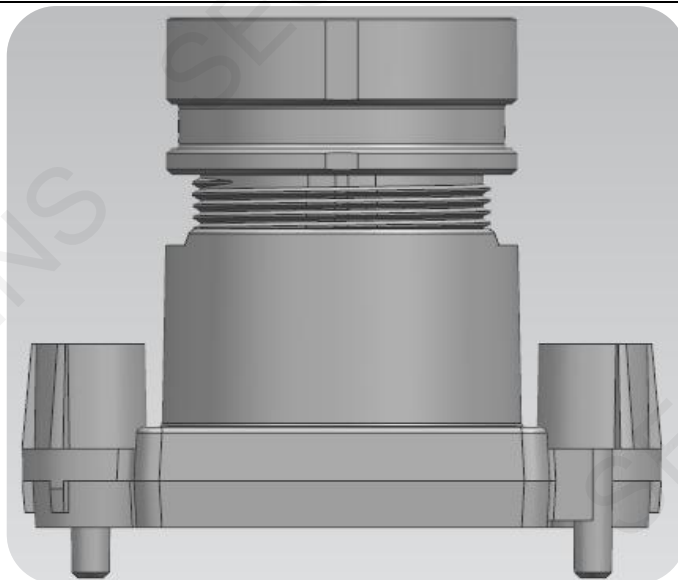

图片仅供参考
(picture only for your reference)

产品规格书目录 (Table of Content)

1 封面(Title Page).....	1
2 目录(Table of Content).....	2
3 变更履历(Revision history).....	3
4 概要(Outline)	
4.1 应用范围(Application).....	4
5 主要参数(Main Items)	
5.1 光学参数规格(Optical Specifications).....	4
5.2 机构参数规格(Mechanical Specifications).....	5
5.3 IR-FILTER规格 (IR-FILTER Specifications)	6
5.4 光学检测标准(Optical Performance).....	7
5.5 环境参数规格(Environment Specifications)	7
6 信赖性测试(Reliability Test).....	8
7 包装规格(Package)	9

3 变更履历 (Revision History) 变更符号标记 (Mark revised) : ○

版本 (REV.)	变更日期 (DATE)	变更内容 (Revision content)	作成 (Prepared by)	备注 (Remark)
1.0	19.05.21	新规作成 (New Spec Document prepared)	ZHY	
1.1				
1.2				
1.3				

4.概要 (Outline)

4.1 应用范围 (Application)

适用于我司向贵司提供的镜头产品(The below datasheet is only suit to SECULENS products.)

5 主要参数 (Main Items)

5.1 光学参数规格 (Optical Specifications)

NO.	项目 (Items)	具体规格 (Specification)					
1	F No.	1.0±10%					
2	焦距(Focal-Length)	6.0 ±5%					
3	光学后焦 (Optical Back Focal Length)	4.79 ±0.2 (in air)					
4	机械后焦 (Mechanical Back Focal Length)	4.11 ±0.2 (in air)					
5	镜头总长(TTL)	22.20 ±0.2 (in air)					
6	像面大小 (Image circle)	Φ6.8 (MAX)					
7	镜片构成 (Lens structure)	3G3P (第一枚镜片为塑胶镜片时, 仅可使用酒精擦拭3次) (The first optical lens is plastic lens, could only be wiped with alcohol 3 times)					
8	接口 (Mount)	M12*P0.5					
9	镜头与底座螺纹配合扭力 (Clamp Force)	60-600gf-cm					
10	视场角(FOV)	sensor型号	H(水平)	V(垂直)	D(对角)		
		1/2.7"(16:9)	57.2°	31.4°	66.5°		
		1/2.8"(16:9)	55.2°	30.3°	64.1°		
		1/2.9"(16:9)	53.2°	29.2°	61.6°		
11	光学畸变 (Optical Distortion)	1/2.7"	-16.4%	1/2.8"	-15.3%	1/2.9"	-14.2%
12	相对亮度 (Relative Illumination)	1/2.7"	39%	1/2.8"	41%	1/2.9"	43%
13	最大主光线夹角 (CRA)	1/2.7"	14.3°	1/2.8"	13.9°	1/2.9"	13.4°
14	近摄距 (M.O.D)	0.2m					
15	解像标准 (Resolution)	分辨率 (Resolution): 1920*1080 (2MP)					
16	重量 (Weight)	/					
17	操作方法 (Operation)	聚焦 (Focus)		手动 (Manual)			
		光圈 (Iris)		固定 (Fixed)			
18	环保&安全 (HSF&Safety)	RoHS					

5.2 机构参数规格 (Mechanical Specifications)

5.2.1 外形尺寸图 (Dimension Figure)

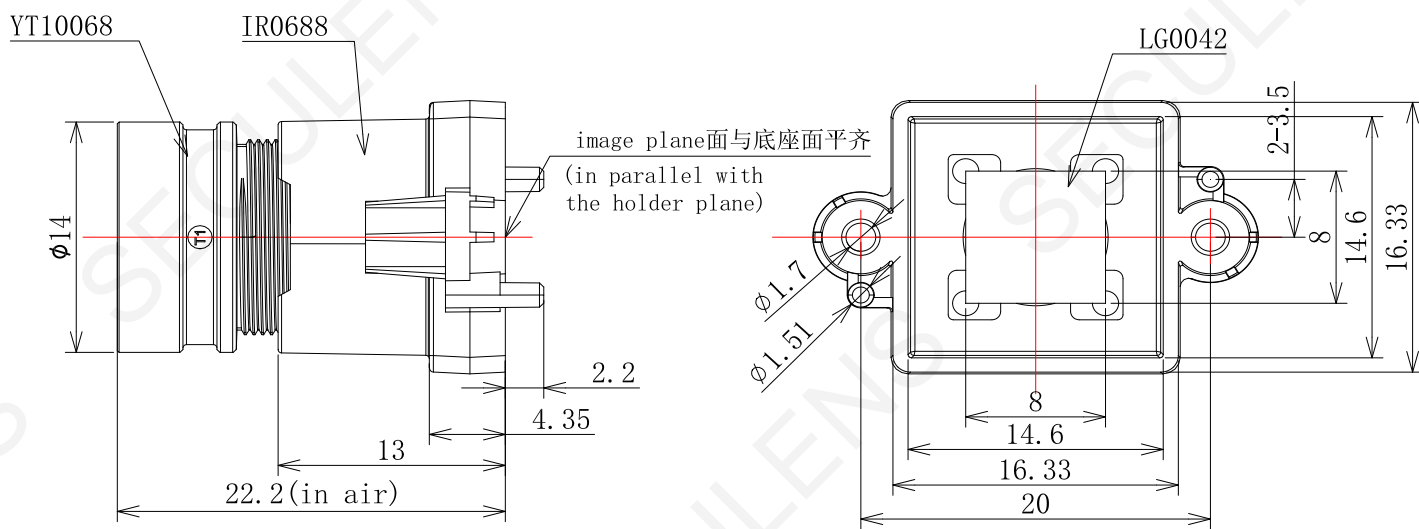

5.2.2 视点图 (Viewpoint Figure)

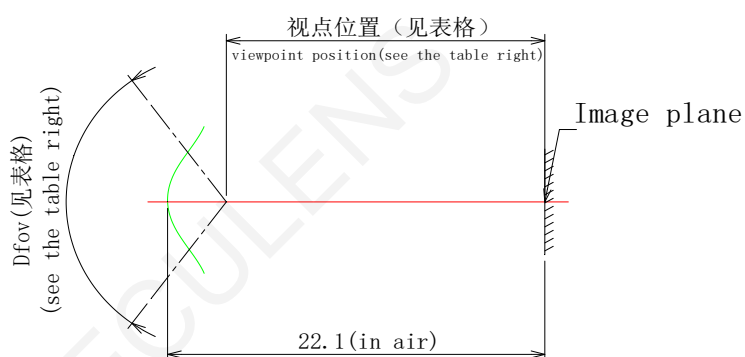

像面大小 (image size)		Dfov	视点位置 (mm) (viewpoint position)
(1/2.7 以下芯片) (Sensor format < 1/2.7")	$\phi 4.41$	43.2°	12.6
	$\phi 5.6$	55.5°	14.53
	$\phi 6.0$	59.8°	15.04
	$\phi 6.17$	61.6°	15.25
	$\phi 6.39$	64.1°	15.51
	$\phi 6.61$	66.5°	15.75
	$\phi 7.0$	70.8°	16.15

未注公差 (Unmarked Tolerance): $\Phi \pm 0.1$, $L \pm 0.15$

本规格书未注单位 (Unit is not indicated in the document.): mm

5.4 光学检测标准 (Optical Performance)

No.	检测项目 (Items)	描述 (Description)
1	解像力 (Resolution)	<p>1.1: TV实拍解像条件 (Condition) A:Chart:社内实拍chart B:实拍距离(Distance): 8.3m</p> <p>1.2: 实拍方法(Method) A:旋转镜头调焦得到最清晰的像面中心(Adjust the machine interface to get the most clear image plane center)</p> <p>1.3: 实拍标准(Criteria) 2MP:中心125线清晰闪烁, 3mm干涉纹两对; 四角: 100线闪烁, 75线清晰闪烁2cm; (Center 125 line Clear flicker, 3mm interference tattoo two pairs; Four Corners: 100 line Flicker, 75 line clear flashing 2cm;)</p>
2	外观标准 (Appearance Standards)	<p>2.1镜头内污 (LENS DUST) A:规格 60-40 伤痕: 宽度 <60um, 长度和 <D/2, ≤15um不计; 脏污: 单点直径 <200um, 100~200um点 ≤3个。</p> <p>2.2其他外观(Other appearance) 外表面颜色均匀, 无明显缺陷、污渍、异物伸出、明显划伤和收缩; 胶水不得溢入有效通光内。</p> <p>2.1 LENS DUST A: Specification 60-40 Scratch: width<60um, total length<D/2, ≤15um ignored; Smudge: Single dot diameter <200um, 100~200um dot ≤3 pcs</p> <p>2.2 Other appearance Outside surface uniform color; no visible flaws, stains, foreign bodies extended, obvious scratch or contraction; no glue spill into the effective aperture.</p>

5.4 环境参数规格 (Environment Specifications)

No.	环境描述 (Items)	条件(Description)
1	存放环境 (Storage condition)	-30℃~+80℃; 10-90%RH (No condensing)
2	工作环境 (Operation condition)	-20℃~+60℃; 10-90%RH (No condensing)

6 信赖性测试(Reliability Test)

No.	项目 (ITEM)	测试条件 (CONDITION)
1	高温存放试验 Storage Test At High Temperature	镜头在80℃温度中存放48小时，之后再存放在常温常湿环境中恢复6小时后，所有规格满足规定要求 All specification are to be satisfied after lens is exposed to 80℃ for 48 hours and then to normal temperature/humidity for 6 hours
2	低温存放试验 Storage Test At Low Temperature	镜头在-30℃温度中存放48小时，之后再存放在常温常湿环境中恢复6小时后，所有规格满足规定要求 All specification are to be satisfied after lens is exposed to -30℃ for 48 hours and then to normal temperature/humidity for 6 hours
3	冷热冲击试验 Temperature Cycle Test	镜头在-30℃条件下保持30分钟，然后升温至+80℃，稳定后保持30分钟作为一个周期，共10个周期。之后再存放在常温常湿环境中恢复6小时后，所有规格满足规定要求 All specification are to be satisfied after lens is exposed to -30℃ for 30min, Tank temperature change +80℃ for 30min as one cycle, 10 cycle shall be performed. And then to normal temperature/humidity for 6 hours
4	振动试验 Vibration Test	镜头在振幅为1.5mm、频率为10-55Hz的正弦波参数下，在三个互相垂直的轴线上依次振动25分钟后，镜头无松动并满足所有规格要求 All specification are to be satisfied after lens is subjected to the sine wave of 1.5mm amplitude and 10-55Hz directions for 25 minutes each

7 包装规格 (Package)

1. 镜头盖上镜头盖后，放入泡壳。

2. 盖上泡壳上盖，泡壳上贴标示票。

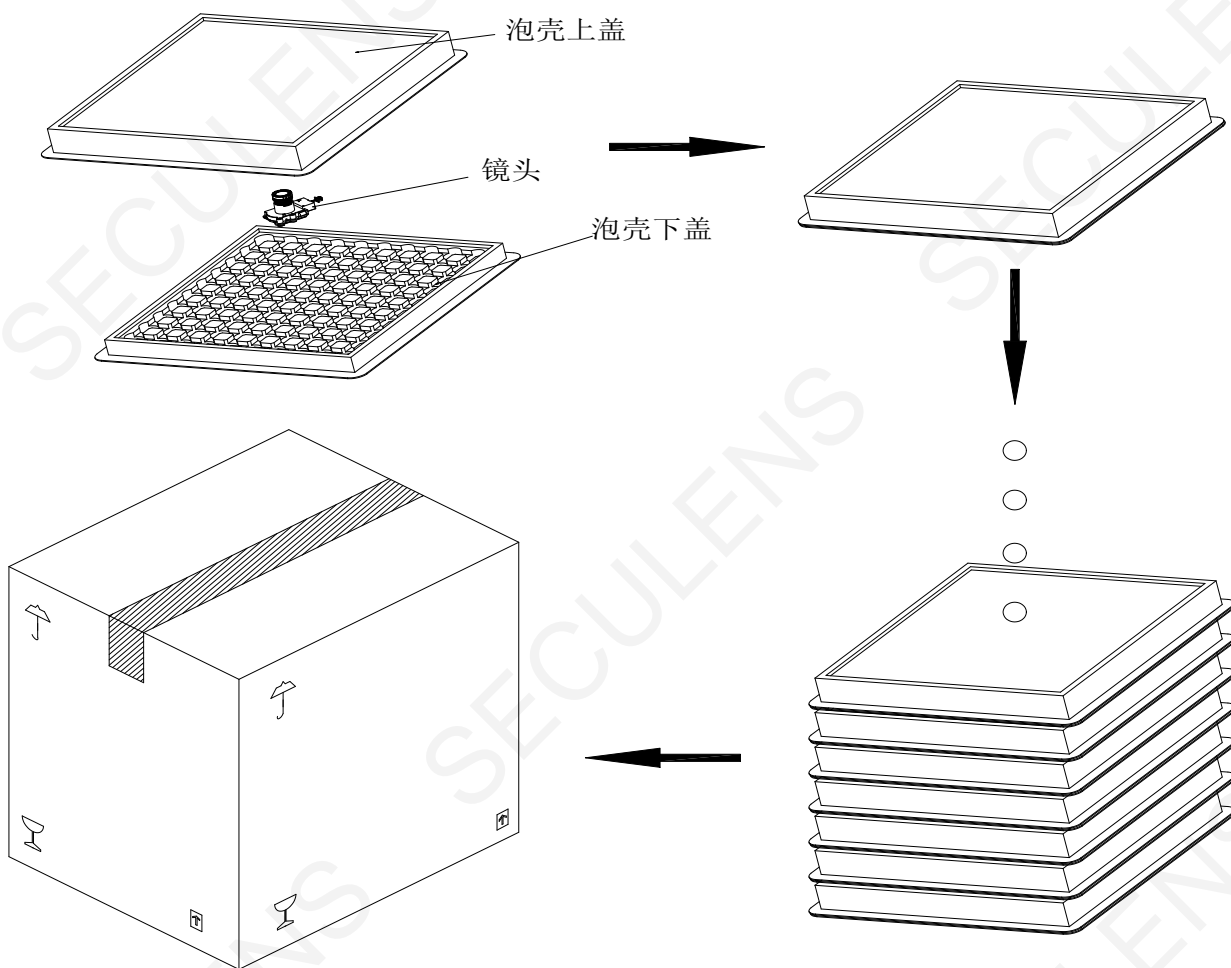

4. 密封胶带，箱子外面贴标示票。

3. 装满镜头的泡壳抽真空后重叠放入纸箱。

注：包装纸箱可根据客户订单灵活选用，以上包装以纸箱（320*240*490）包装示例

数量：

 待定 PCS/盒

 待定 盒/箱

 待定 PCS/箱