



创威中科[®]
CWZK



SECULENS[®]

深圳市创威时代光电有限公司

Shenzhen ChuangWei Seculens CO., Ltd.

产品规格书

Product Specification

型号:

(Model Name) :

YT10169-3MP+IR0760

编码:

(Part No.) :

01.10169.003.03

客户名称:

(Customer Name):

客户编码:

(Customer Part No.):

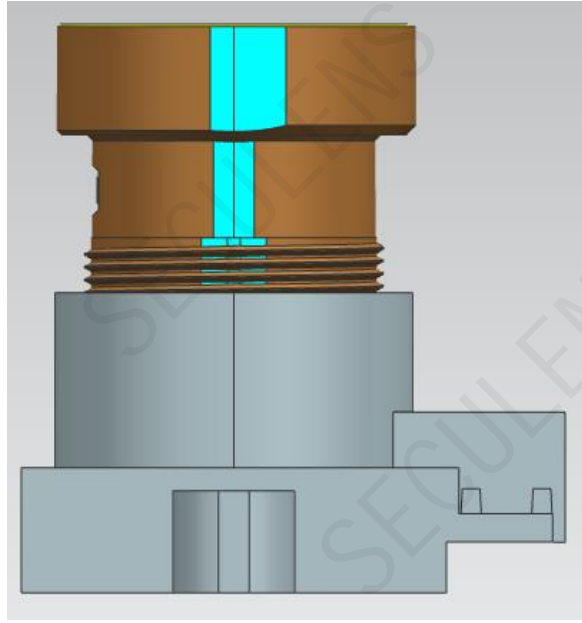

图片仅供参考
(picture only for your reference)

产品规格书目录 (Table of Content)

1 封面(Title Page).....	1
2 目录(Table of Content).....	2
3 变更履历(Revision history).....	3
4 概要(Outline)	
4.1 应用范围(Application).....	4
5 主要参数(Main Items)	
5.1 光学参数规格(Optical Specifications).....	4
5.2 机构参数规格(Mechanical Specifications).....	5
5.3 IRCUT参数规格(IRCUT Specifications).....	6
5.4 光学检测标准(Optical Performance).....	7
5.5 环境参数规格(Environment Specifications).....	7
6 信赖性测试(Reliability Test).....	8
7 包装规格 (Package)	10



3 变更履历 (Revision History) 变更符号标记 (Mark revised) : ○

版本 (REV.)	变更日期 (DATE)	变更内容 (Revision content)	作成 (Prepared by)	备注 (Remark)
1.0	22.12.09	新规作成 (New Spec Document prepared)	ZYQ	
1.1	23.01.12	更新相对照度	ZYQ	

4.概要 (Outline)

4.1 应用范围 (Application)

适用于我司向贵司提供的镜头产品(The below datasheet is only suit to CWZK products.)

5 主要参数 (Main Items)

5.1 光学参数规格 (Optical Specifications)

NO.	项目 (Items)		具体规格 (Specification)					
1	F No.		1.4±10%					
2	焦距(Focal-Length)		3.9±5%					
3	光学后焦 (Optical Back Focal Length)		5.24±0.2 (in air)					
4	机械后焦 (Mechanical Back Focal Length)		5.10±0.2 (in air)					
5	镜头总长(TTL)		22.26±0.2 (in air)					
6	像面大小 (Image circle)		Φ7 (MAX)					
7	镜片构成 (Lens structure)		1G4P (第一枚镜片为塑胶镜片时, 仅可使用酒精擦拭3次) (The first optical lens is plastic lens, could only be wiped with alcohol 3 times)					
8	接口 (Mount)		M12*P0.5					
9	镜头与底座螺纹配合扭力 (Clamp Force)		60-600gf.cm					
10	视场角 (FOV)	sensor型号	H(水平)		V(垂直)		D(对角)	
		1/2.7" (5.76*3.24*6.609)	90.3°		47.7°		108.4°	
		1/2.8" (5.568*3.132*6.388)	86.6°		46.0°		103.4°	
		1/2.9" (5.376*3.024*6.168)	83.0°		44.4°		98.6°	
11	光学畸变 (Optical Distortion)		1/2.7"	-39%	1/2.8"	-35%	1/2.9"	-32%
12	TV畸变 (TV Distortion)		1/2.7"	-12.7%	1/2.8"	-11.7%	1/2.9"	-10.8%
13	相对亮度 (Relative Illumination)○		1/2.7"	37.3%	1/2.8"	39.8%	1/2.9"	42.2%
14	最大主光线夹角 (CRA)		1/2.7"	15.45°	1/2.8"	14.87°	1/2.9"	14.28°
15	近摄距 (M.O.D)		1m					
16	解像标准 (Resolution)		分辨率 (Resolution): 2048*1536 (3MP)					
17	建议芯片封装倾斜规格 (tilt tolerance of sensor packaging)		/					
18	重量 (Weight)		/					
19	操作方法 (Operation)		聚焦 (Focus)		手动 (Manual)			
			光圈 (Iris)		固定 (Fixed)			
20	环保&安全 (HSF&Safety)		RoHS					

备注: 以上参数均为理论值, 仅供参考

NOTE:The above parameters are theoretical values, for reference only

5.2 机构参数规格(Mechanical Specifications)

5.2.1 外形尺寸图 (Dimension Figure)

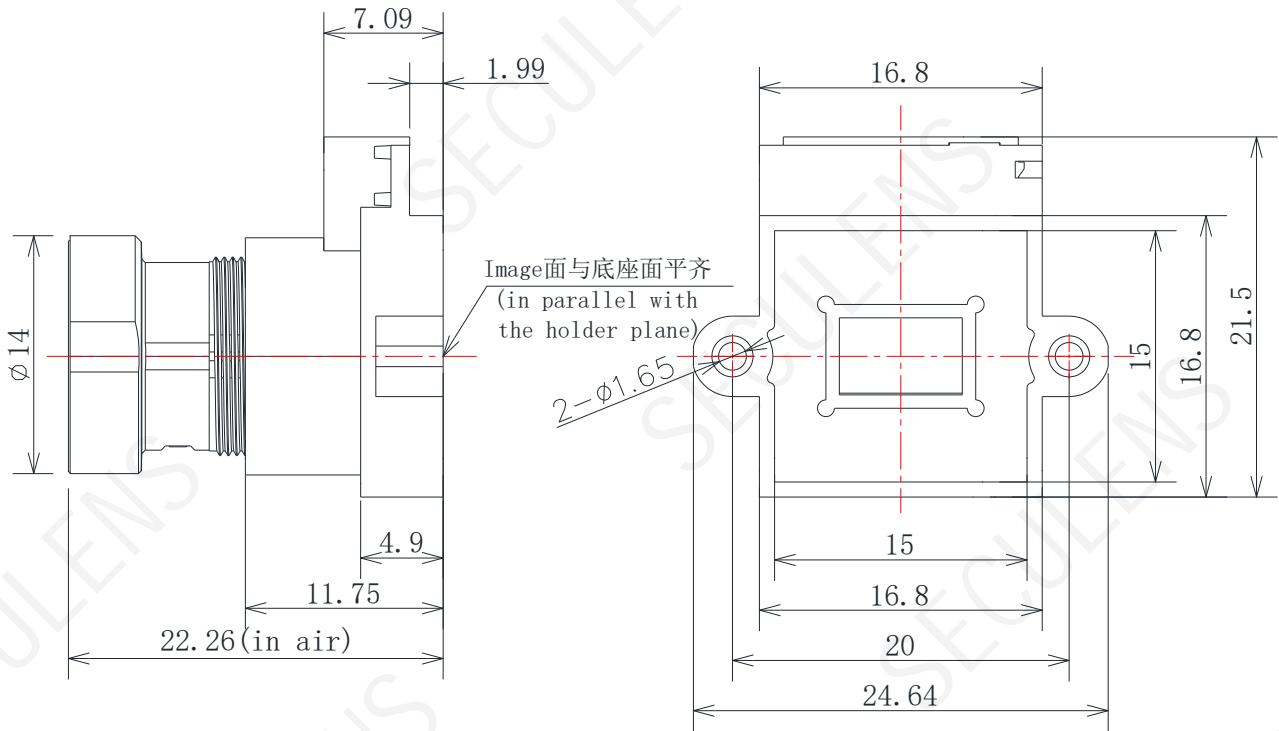

5.2.2 视点图 (Viewpoint Figure)

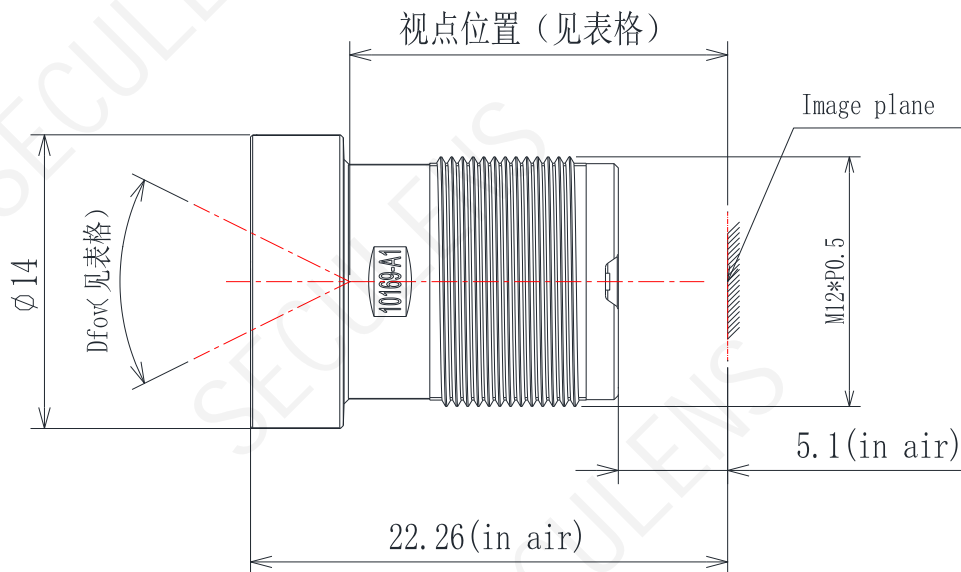

本规格书未注单位(Unit is not indicated in the document): mm

未注公差(Unmarked Tolerance): $\Phi \pm 0.1$, $L \pm 0.15$

5.2.3 视点信息 (Viewpoint table):

全像高 full image	视场角 FOV	视点 viewpoint	备注 remark	全像高 full image	视场角 FOV	视点 viewpoint	备注 remark
2.1	30.7°	14.84		6.9	115.4°	19.83	
2.2	32.2°	15.06		7	118.0°	19.94	
2.3	33.6°	15.26		7.1			
2.4	35.1°	15.45		7.2			
2.5	36.6°	15.62		7.3			
2.6	38.1°	15.79		7.4			
2.7	39.6°	15.94		7.5			
2.8	41.0°	16.09		7.6			
2.9	42.5°	16.23		7.7			
3	44.0°	16.36		7.8			
3.1	45.6°	16.48		7.9			
3.2	47.1°	16.60		8			
3.3	48.6°	16.72		8.1			
3.4	50.1°	16.83		8.2			
3.5	51.7°	16.94		8.3			
3.6	53.2°	17.04		8.4			
3.7	54.8°	17.14		8.5			
3.8	56.3°	17.24		8.6			
3.9	57.9°	17.33		8.7			
4	59.5°	17.43		8.8			
4.1	61.1°	17.52		8.9			
4.2	62.7°	17.60		9			
4.3	64.4°	17.69		9.1			
4.4	66.0°	17.78		9.2			
4.5	67.7°	17.86		9.3			
4.6	69.3°	17.94		9.4			
4.7	71.0°	18.02		9.5			
4.8	72.8°	18.10		9.6			
4.9	74.5°	18.18		9.7			
5	76.2°	18.26		9.8			
5.1	78.0°	18.34		9.9			
5.2	79.8°	18.42		10			
5.3	81.6°	18.50		10.1			
5.4	83.5°	18.58		10.2			
5.5	85.3°	18.66		10.3			
5.6	87.2°	18.73		10.4			
5.7	89.2°	18.81		10.5			
5.8	91.1°	18.89		10.6			
5.9	93.1°	18.97		10.7			
6	95.1°	19.05		10.8			
6.1	97.2°	19.13		10.9			
6.2	99.3°	19.21		11			
6.3	101.5°	19.29		11.1			
6.4	103.6°	19.38		11.2			
6.5	105.9°	19.46		11.3			
6.6	108.2°	19.55		11.4			
6.7	110.5°	19.64		11.5			
6.8	112.9°	19.74		11.6			

备注:

1. 最大像高提供至镜头支持的最大靶面 (通用产品相对照度按照20%, 特殊产品根据需求再联络)
2. 视点深度一律按照空气中尺寸计算; 并且以镜头像面为起始位置;
3. 模拟参数时, 物距暂定按照无穷远计算——此时镜头距离前窗玻璃最远, 干涉风险最大;
4. 各数据的公差按照: 视场角精确到0.1度, 视点精确到0.01mm;

NOTE:

1. The max image height is the largest format that the lens can support (general RI is 20%);
2. It is in air depth of viewpoint; counting from lens image .
3. Simulated object distance is infinite.
4. tolerance: FOV 0.1° ; viewpoint 0.01mm.

5.3 IR-CUT参数规格 (IR0760) (IRCUT Specification)-V02

NO	项目ITEM	条件Condition	单位Unit	标准Standard
1	产品外形尺寸(Product size)	装配外形(Assembly exterior)	mm	24.64*21.5*11.75
2	开放口径(Openning Aperture)	-	mm	7*3.8
3	线长(Wire Length)	-	mm	70±5
4	线径(Wire diameter)	-	mm	0.6
5	绝缘等级(Insulation class)	-	-	A
6	端子保持力(Terminal retentivity)	-	N	≥10
7	线圈阻抗(Coil Resistance)	20°C	Ω	20±5
8	静态保持力(Static retention force)	-	g	≥0.6
9	通电电压(Electric voltage)	参照环境参数规格Refer to the environmental parameter specifications	V	3.5~6
10	通电时间(Electric time)	参照环境参数规格Refer to the environmental parameter specifications	ms	100~200
11	推荐驱动条件(Recommend Driving Condition)	参照环境参数规格Refer to the environmental parameter specifications	-	端口电压Port voltage: 3.5V 驱动秒时Driving time: 100ms

备注：产品通正反向电压，通断电时间为：通电100ms~200ms，断电30s~60s，不通电时滤光片保持不动。

Note: Positive and negative voltage. Time: power on 100ms ~200ms, power off 30s~60s. Filter does not move when power is off

滤光片规格 (IR Filter Specifications)

红外波光片 (IR Filter)	镀膜方式 (Coating method)	单面镀膜Single sided coating	
	滤光片基材 (Base material)	光学玻璃	
	尺寸 (Size)	8.3mm*5.0mm*0.21mm(厚度公差±0.02mm)	
	镀膜规格 (Coating Spec)	350nm~380nm	Tave<3%
		420nm±10nm	T=50% 斜率20%~80%<20nm
		440nm~600nm	T>85% Tave>93%
		645nm±10nm	T=50% 斜率80%~20%<20nm
680nm	T<5%		
700nm~950nm	Tave<1% T<1%		
白片波光片 (Dummy Glass)	镀膜方式 (Coating method)	双面镀膜Double sided coating	
	滤光片基材 (Base material)	光学玻璃	
	尺寸 (Size)	8.3mm*5.0mm*0.21mm(厚度公差±0.02mm)	
	镀膜规格 (Coating Spec)	420nm~950nm T>92% Tave>96%	

切换模式 (Switch type)

区分 Distinction	红线Red line	黑线Black line	状态State
极性Polarity	(-)	(+)	白玻璃片工作 (夜晚) Dummy glass work
	(+)	(-)	红外滤光片工作 (白天) IR Filters work

端子定义terminal:

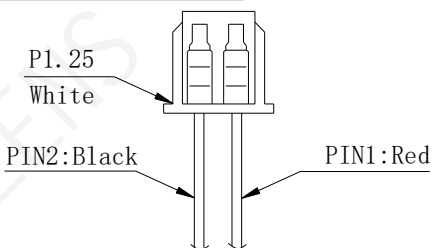

接线示意图wiring diagram:

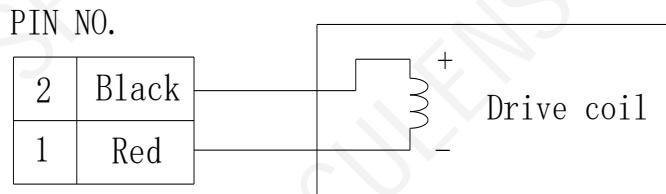

5.4 光学检测标准 (Optical Performance)

No.	检测项目 (Items)	描述 (Description)
1	解像力 (Resolution)	<p>1.1: TV实拍解像条件 (Condition) A:Chart:社内实拍chart B:拍摄距离(Distance): 1.2m</p> <p>1.2: 拍摄方法(Method) A:旋转镜头调焦得到最清晰的像面中心(Adjust the machine interface to get the most clear image plane center)</p> <p>1.3: 拍摄标准(Criteria) 3MP: 拍摄 (resolution test) 中心: 1000线条清晰; 0.7Y: 700线条清晰; 0.9Y: 300线条清晰; Center:1000 line clear;0.7Y:700 line clear;0.9Y: 300 line clear</p>
2	外观标准 (Appearance Standards)	<p>2.1镜头内污 (LENS DUST) A:规格 60-40 (27W台灯目视检查) 伤痕: 宽度 <60um, 长度和 <D/2, ≤15um不计; 脏污: 单点直径 <400um,200~400um 点 ≤3个。</p> <p>2.2IR-CUT外观(IR-CUT appearance) A:滤光片油污、异色、欠膜、破裂、溢胶、水纹、白雾, 不可; B:表面不可移动脏污, 尘点范围要求: 如右图所示: ①区0.1mm以下不可超过3个; ②区0.1~0.15mm不可超过5个; ③区0.1~0.2mm以下不可超过10个。图中①和②区划伤长度1mm,宽度0.1mm≤3个。 C:可移动尘点的全区依照中心位置不可移动尘点标准判定 D:丝印不良不可</p> <p>2.3其他外观(Other appearance) 外表面颜色均匀, 无明显缺陷、污渍、异物伸出、明显划伤和收缩; 胶水不得溢入有效透光内。</p> <p>2.1 LENS DUST A: Specification 60-40 (Visual inspection of the 27W desk lamp) Scratch: width<60um, total length<D/2, ≤15um ignored; Smudge: Single dot diameter <400um,200~400um dot ≤3 pcs</p> <p>2.2 IR-CUT appearance A: Oil on filter, color failure, coat cracks, coating missing, glue overflow, liquid pattern are not acceptable. B: Standard for immovable dirt-spot on surface, Referring the image on the right side: 1) Area <0.1mm, spot ≤3; 2) Area 0.1~0.15mm, spot ≤5; 3) Area 0.1~0.2mm, spot ≤10; 4) Area 1) and 2)'s spot, with length is around 1mm and width around 0.1mm, ≤3 C: Movable dirt-spot's standard is following the immovable standard D: Printed letter's failure is not acceptable</p> <p>2.3 Other visual standard Color on surface is even, not obvious defect, dirt, dislocation, scratch, shrink; glue is not allowed to enter the effective diameter range.</p> 

5.5 环境参数规格 (Environment Specifications)

No.	环境描述 (Items)	条件(Description)
1	存放环境 (Storage condition)	-30℃~+80℃; 10-90%RH (No condensing)
2	工作环境 (Operation condition)	-20℃~+60℃; 10-90%RH (No condensing)

6 信赖性测试(Reliability Test)

No.	项目 (ITEM)	测试条件 (CONDITION)	判定标准 (standard of criterion)
1	高温存放试验 Storage Test At High Temperature	镜头在80℃温度中存放48小时，之后再存放在常温常湿环境中恢复6小时后，所有规格满足规定要求 All specification are to be satisfied after lens is exposed to 80℃ for 48 hours and then to normal temperature/humidity for 6 hours	变化20%以内；回常温中心变化50本，周边100本以内 after test, resolution change $\leq 20\%$; resolution change ≤ 50 lines when lens temperature return to room temperature
2	低温存放试验 Storage Test At Low Temperature	镜头在-30℃温度中存放48小时，之后再存放在常温常湿环境中恢复6小时后，所有规格满足规定要求 All specification are to be satisfied after lens is exposed to -30℃ for 48 hours and then to normal temperature/humidity for 6 hours	变化20%以内；回常温中心变化50本，周边100本以内 after test, resolution change $\leq 20\%$; resolution change ≤ 50 lines when lens temperature return to room temperature
3	冷热冲击试验 Temperature Cycle Test	镜头在-30℃条件下保持30分钟，然后升温至+80℃，稳定后保持30分钟作为一个周期，共10个周期。之后再存放在常温常湿环境中恢复6小时后，所有规格满足规定要求 All specification are to be satisfied after lens is exposed to -30℃ for 30 min, Tank temperature change +80℃ for 30 min as one cycle, 10 cycle shall be performed. And then to normal temperature/humidity for 6 hours	变化20%以内；回常温中心变化50本，周边100本以内 after test, resolution change $\leq 20\%$; resolution change ≤ 50 lines when lens temperature return to room temperature
4	振动试验 Vibration Test	频率：加速度谱密度 1Hz 0.00072 g ² /Hz; 3.0Hz 0.018 g ² /Hz; 4.0Hz 0.018 g ² /Hz; 5.0Hz 0.01 g ² /Hz; 100.0 Hz 0.01 g ² /Hz; 135.0 Hz 0.00148 g ² /Hz; 200.0 Hz 0.001 g ² /Hz; 201.0 Hz 0.00012 g ² /Hz; 300.0 Hz 0.00001 g ² /Hz; 总均方根加速度：1.087Grms 试验轴向：3轴向。 试验时间：Z方向60min, X和Y方向30min 对于A类包装（包装件重量 ≤ 45 KG）：起始频率点为5Hz	变化20%以内； after test, resolution change $\leq 20\%$;

No.	项目 (ITEM)	测试条件 (CONDITION)	判定标准 (standard of criterion)
5	耐久试验 (Durability)	<p>试验标准:</p> <ul style="list-style-type: none"> ▪ VCM马达: <ul style="list-style-type: none"> 电流: 0~90~0 mA , 持续1秒 Current : 0~90~0 mA for 1sec 方向: +Z 方向 Direction : +Z direction 周期: 1轮=0.5秒开启→ 0.5s 关闭 Cycle : 1cycle= 0.5s ON→ 0.5s OFF 温度: 23C° ±2C° Temperature : 23C° ±2C° 时间: 300,000轮 Times : 300,000cycles ▪ IR-cut filter section <ul style="list-style-type: none"> IN ≡ OUT 驱动100ms, 断电2500ms 往复驱动, 20000次 0.5 ~ 1.0 seconds for each reciprocating 20,000 times <p>测试项目:</p> <p><input checked="" type="checkbox"/> IR-cut <input type="checkbox"/> VCM马达 <input type="checkbox"/> 不涉及</p>	<p>试验后各项性能OK; all meet test standard after test</p>
6	跌落试验 (drop test)	<p>1. 高度: 包装后, 高度1m; 2. 落下方向: 一角三棱六面; 3. 次数: 各一次; 上述实验条件后作动无异常。(NO abnormalities for operation after testing with above experiment conditions)</p> <p>1.Height: 1m after packaged; 2.Direction: A triangular prism with six faces; 3.NO abnormality after experiment above all.</p>	<p>试验后各项性能OK; all meet test standard after test</p>

7 包装规格 (Package)

1. 镜头盖上镜头盖后，放入泡壳。

2. 盖上泡壳上盖，泡壳上贴标示票。

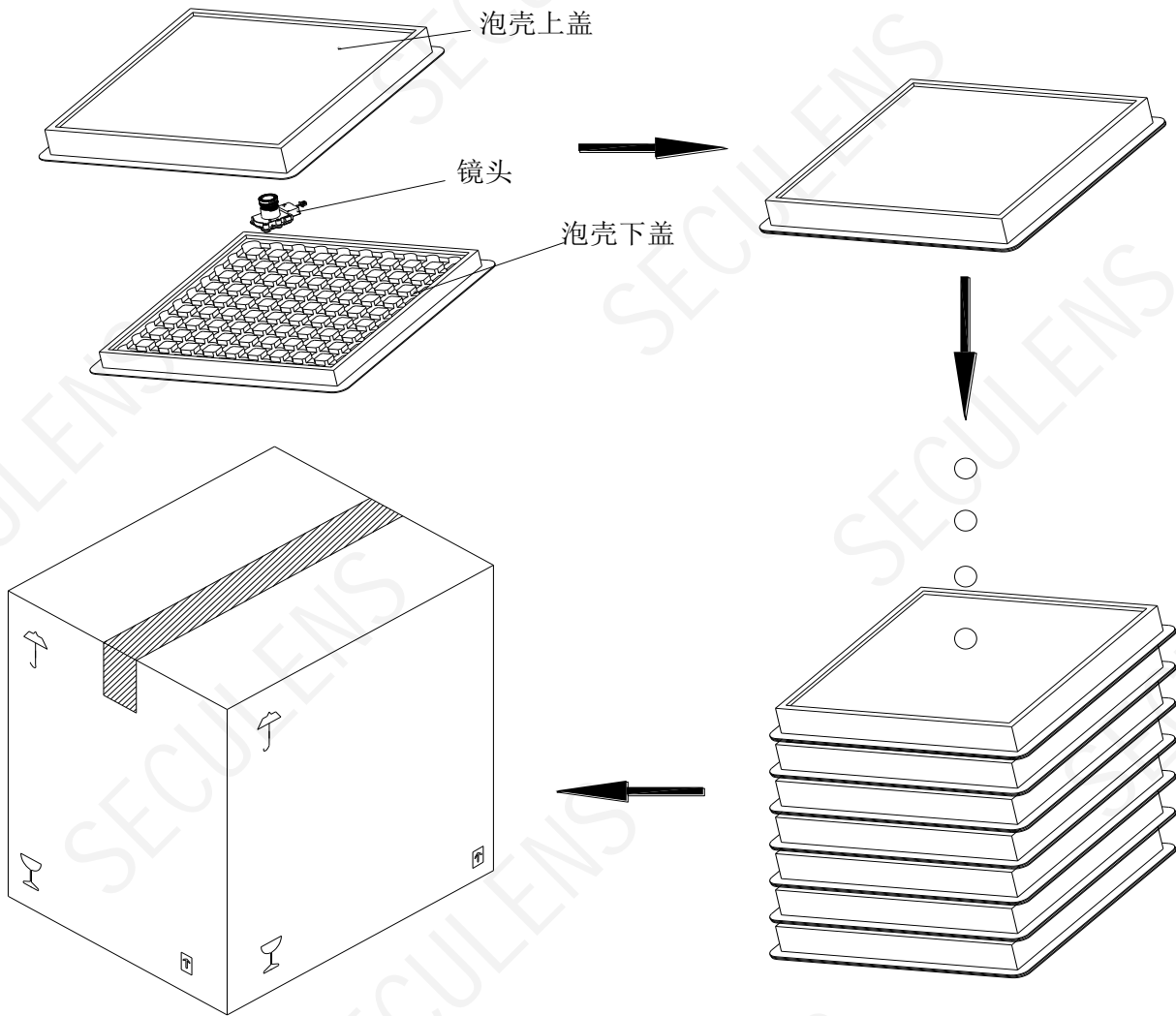

4. 密封胶带，箱子外面贴标示票。

3. 装满镜头的泡壳抽真空后重叠放入纸箱。

注：包装纸箱可根据客户订单灵活选用，以上包装以纸箱（320*240*490）包装示例

数量：

待定 PCS/盒

待定 盒/箱

待定 PCS/箱